

C YOU LATER

THE NEW C330v



SEALINE



WE'RE OFF TO FOLLOW THE SUN





enjoy the
LIGHT

feel the
SPACE

combine functionality with
DESIGN

All Sealine yachts are born of the same values: They feature wide interior spaces, an amazing quantity of natural light and outstanding design with German engineering inside. As for these trademarks, the C330v displays the true spirit of Sealine.

SEALINE C330v

SEALINE: THE YACHT

FUN-TO-DRIVE OUTBOARDS

Driving the C330v is spontaneous and entertaining. The outboards' quiet operation ensures life on board to be a pleasure.

TWO OPENING ROOF SECTIONS

Maximum versatility and comfort for the guests. Shade and sun where you need them.

TEAK PLATFORM ON EACH SIDE

Two swimming platforms have been placed around the outboards to ensure everyone goes in and out the water easily.

BIFOLD DOOR & TILTING WINDOW

In the aft you can blur the line between inside and outside: open the bifold door and the tilting window to the cockpit bar.



THAT HAS IT ALL



DYNAMIC HULL DESIGN

The sculptured hull provides excellent performance whilst giving light and space to the interior.

TWO GENEROUS SUN LOUNGES

Sunbathing for all your guests. In addition to the sunbed at the fore, the cockpit table can be transformed into a comfortable lounge.

STARBOARD SLIDING DOOR

Step out through the almost invisible glass door on the starboard side to walk on the bow area.



LET YOUR FEELINGS RUN FREE

The new Sealine C330v combines the intelligent all-weather design of the Sealine Cruiser series with the agility of two outboards. Rediscover the feeling of spontaneity and independence on this yacht!

The Sealine C330v shows its versatility in two simple steps: fold the sliding door to one side and open the window to the cockpit. This way you create a seamless, open space with the cockpit bar at the centre. Here you can present fresh snacks and drinks in such an inviting way that your guests will soon be in the party mood.



C330V

SEALINE

SEALINE



C330V

SEALINE

330V



On the Sealine C330v you experience many facets of freedom. Two sun decks, one forward and one aft, invite you to relax. The large glass sunroof immerses the saloon in sunlight, while the retractable soft-top lets you set just the right amount of shade in the cockpit.

Meanwhile, the twin outboards are ready to enrich your on board life with action-packed moments. Offering 2 x 300hp, the Sealine C330v easily accelerates to a speed of up to 40 knots.



WHEN YOUR STYLE AND THE SEA OUTSHINE EACH OTHER

The interior of the Sealine C330v brings elegance, luxury and volume into perfect balance. The two double cabins set the benchmark of what is currently possible in the 33ft category in terms of headroom and bed size. Huge hull windows top off this generous space with a view that is remarkably close to the panorama on deck.





GUIDED BY EXCELLENCE CRAFTED BY EXPERTS

The manufacturing quality of the C330v is a multi-sensory experience. Exquisite materials spoil the eye with every glance. A subtle scent of finest leathers blends with the pleasing feel of elegant woods. Anything you see or touch was masterfully handcrafted by superb boat builders. Enjoy an exclusive atmosphere that can only be created by the perfect match of sophisticated details.



YOUR SEALINE IS SECOND TO NONE

With your personal selection of colours and textures, you transform your Sealine into a unique expression. Five teak variants are available for the deck alone. We also offer special materials for cockpit seats and sun cushions. For the interior you can choose between different furniture woods, upholstery and curtains, while underfoot, select from wood or carpet.

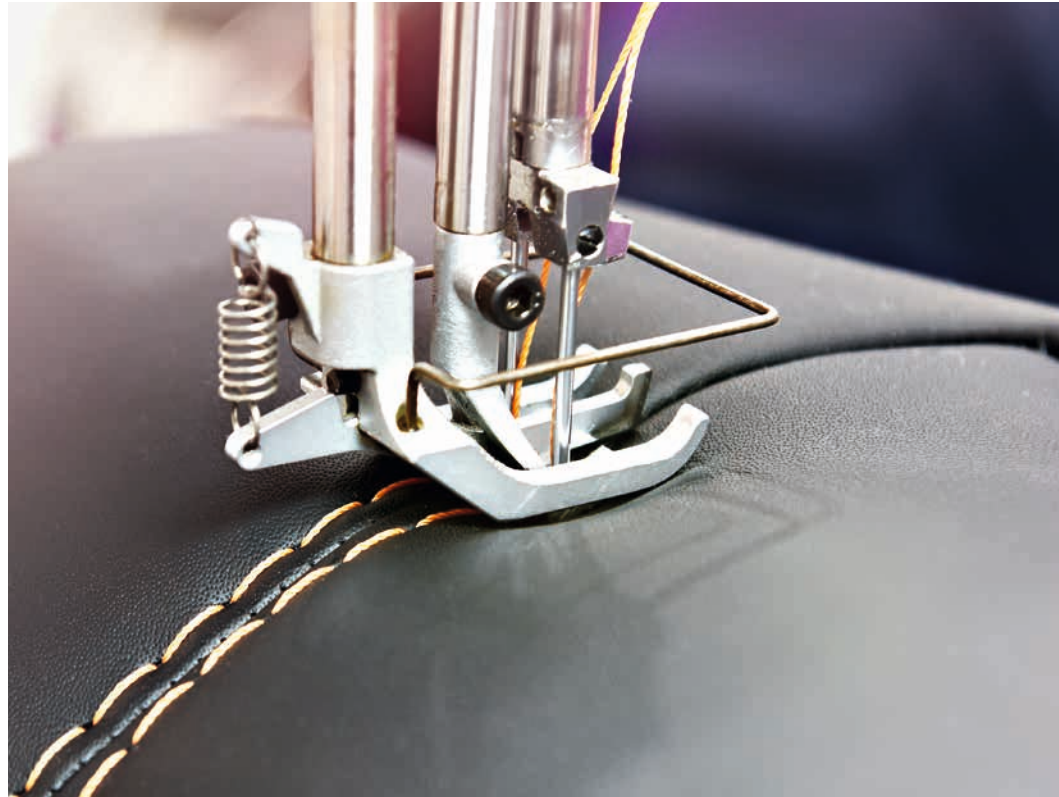

SEALINE C330v



POWERED BY 2 X 300HP

Because outboards direct all their power in the exact direction you steer, they are very agile and great fun to drive. Being able to lift the entire motor out of the water also makes maintenance very easy.



LAMINATED POWER GRID

The hull reinforcements of the Sealine C330v are elaborately laminated – giving you the advantages of a high-strength yacht with a reduced weight.

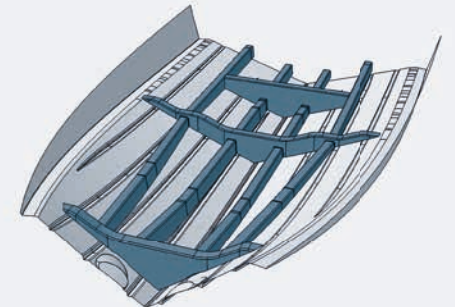



BORN TO PERFORM

Outstanding boating characteristics are part of the Sealine experience. From the shape of the hull to the engines, we have pulled out all the stops to ensure the Sealine C330v gives you special moments on the water.

DEEP V-SHAPED KEEL

The Sealine C330v hull has a deep-V shape. This means the Sealine is exceptionally stable in the water, making for more comfortable boating.

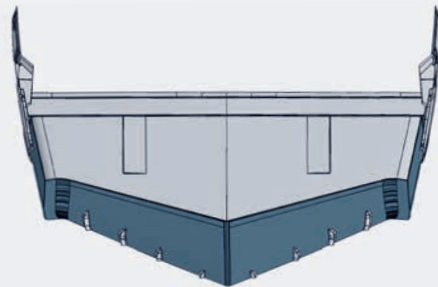

UPRIGHT STEM

The vertical bow with its curved foot pierces the waves elegantly and efficiently. This, in turn, results in more comfort and more boating pleasure.

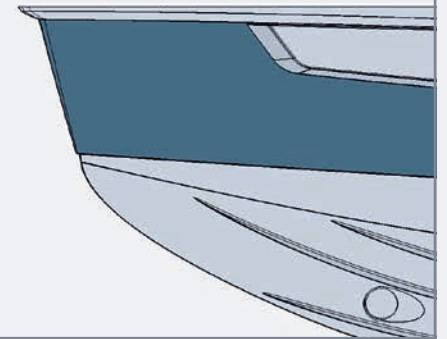



PRINCIPAL DIMENSIONS according to ISO 8666

LOA	10.31 m	33' 10"
LOA ext. platform	11.01 m	36' 1"
LH	10.07 m	33' 0"
Beam	3.50 m	11' 6"
Draught double engine	0.89 m	2' 11"
Height above waterline inc. mast	3.48 m	11' 5"
Height above waterline excl. mast	2.80 m	9' 2"
Fuel capacity	570 l	125 UK gal
Water capacity	220 l	48 UK gal
Displacement approx.	7.27 t	7.16 UK t
Max people on board	8	8
CE Category	B	B

All performance figures are given in good faith and are intended as an indication. These figures cannot be guaranteed as top speed in particular is affected by the cleanliness of the hull, conditions of the propellers, weight carried and air/sea temperature. Performance is related also to the optional accessories selected SEALINE reserves the right to change specifications in line with the company policy of improvement through research and development. Standard Propeller tested in Greifswald according to Volvo conditions. All measurements/figures approximate. Errors and omissions excepted. Specification and material can be changed without notice. Please check with your dealer for a full list of inclusions. Sealine S330v & C330v: Max. outboard horse power: 2x300 hp; max. speed allowed: 40 knots.

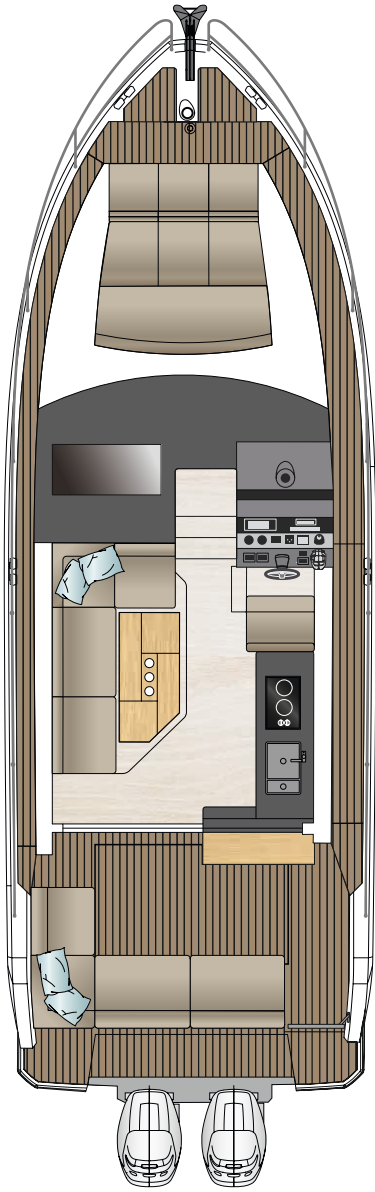

MAINDECK

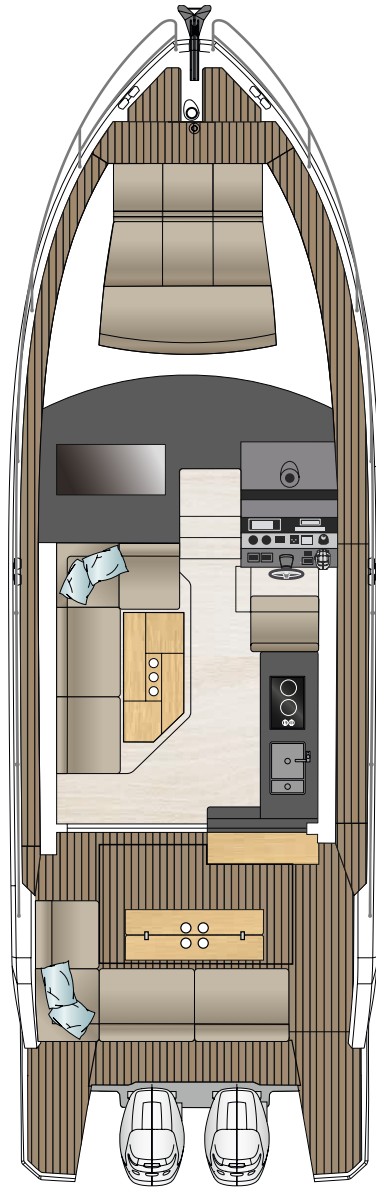

MAINDECK
option

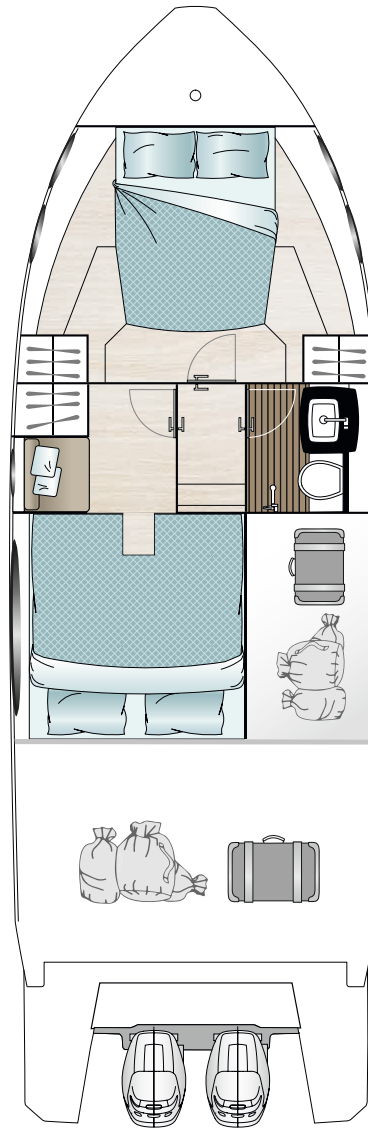

LOWERDECK

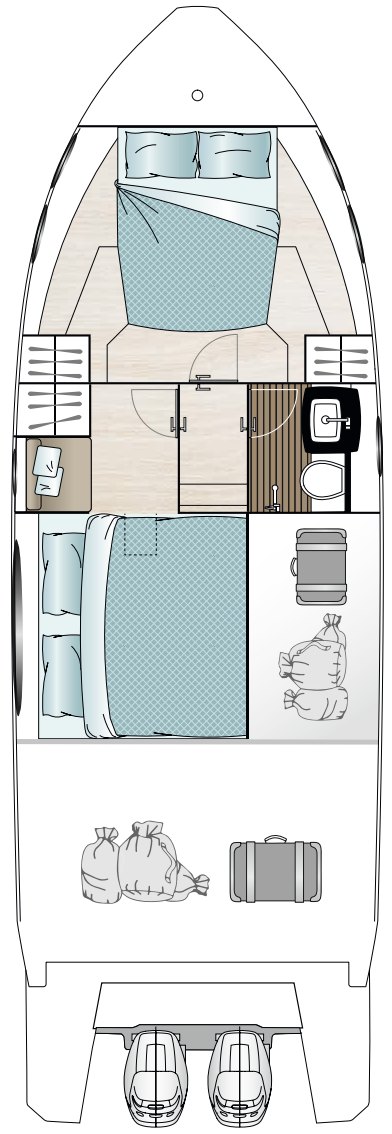

LOWERDECK
option



C330V



C330V



GO TO WHERE THE FREEDOM IS



C330



NEW C330v



S330



S330v



C390



C430



F430



C530



F530



www.sealine.com

Sealine Ladebower Chaussee 11 D-17493 Greifswald